

CoroStar 40

by Ivan C.
Jan. 2005

SPECIFICATIONS:

Wing Span: 64" (1626 mm)
 Fuselage Length: 44" (1118 mm)
 Wing Area: 781 sq.in. (50.4 sq.dm)
 Weight (RTF): 6.0 - 6.5 lb. (2720 - 2950 g)
 Wing Loading: 18 - 19 oz./sq.ft. (54 - 59 g/sq.dm)
 Engine: .40 - .46 cu.in. (6.5 - 7.5 cc)
 Fuel Tank: 8oz. (240 ml) rectangular

MATERIALS USED:

Fuselage: 2-3/8" canadian PVC downspout gutter pipe.
 Bottom Wing Panels, Stab, Fin: 4mm coroplast.
 Top wing panels: 2mm coroplast.
 Wing LE: 1/4" dowel (2 pcs. 32" each running spanwise).
 Main Spar: 4 yardsticks
 Spar Joiner, Spar Spacers, Firewall, Landing Gear Mount : 1/2" ply or hardwood.

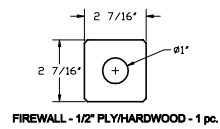
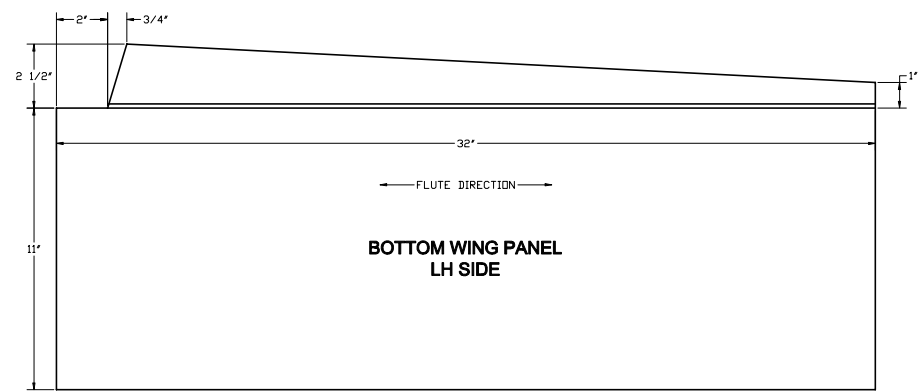
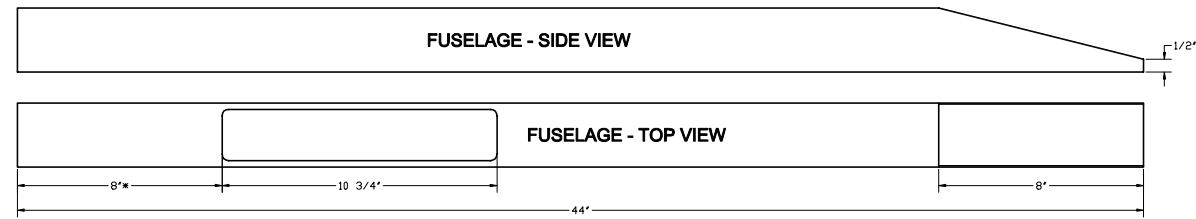
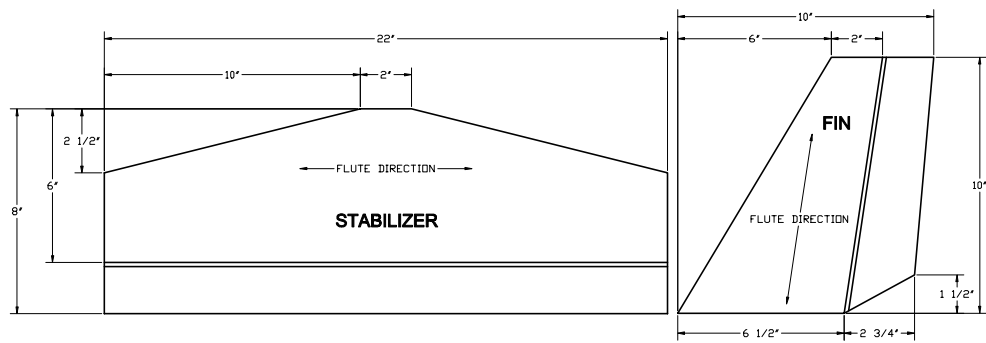

FIREWALL - 1/2" PLY/HARDWOOD - 1 pc.

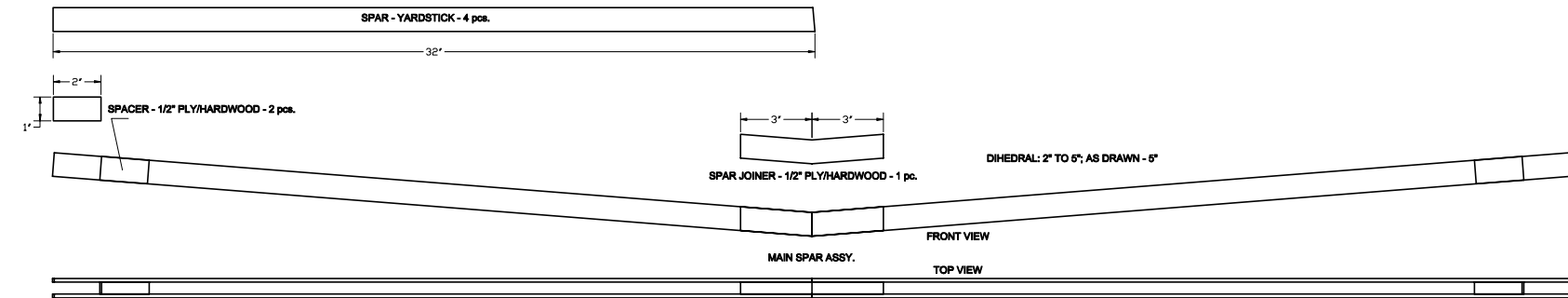

* This dimension to be determined when ballancing the panel

